

Part Number: PT392-34140

Kit Contents

Item #	Quantity Req'd.	Description
1	1	Linkage Assembly
2	1	Mounting Bracket
3	1	Step Pad
4	1	Hardware Bag
5	1	Bumper Support Bracket
6	1	Bumper Re-enforcement Bracket

Hardware Bag Contents

Item #	Quantity Req'd.	Description
1	2	M10 Hex Head Bolt
2	3	¼-20 x 1" SHCS
3	3	¼-20 Nut Plate
4	5	M8 Nut
5	1	¼" Spacer

Additional Items Required For Installation

Item #	Quantity Req'd.	Description
1		

Conflicts

Accessory Hitch (Factory Hitch okay)

Recommended Tools

Personal & Vehicle Protection	Notes
Safety Glasses	
Protective Tape	
Special Tools	Notes
None	
Installation Tools	Notes
Ratchet Wrench	
3" Extension	
19mm Socket	
15mm Socket	
13 mm Socket & Wrench	
12 mm Socket & Wrench	
Flat Blade Screwdriver	Large & Regular
Phillips Screwdriver	
3/16" Allen Wrench	
Torque Wrench	0-150 ft-lbf
Special Chemicals	Notes

General Applicability

--

Recommended Sequence of Application

Item #	Accessory
1	Bumper Step Assist
2	TRD Exhaust

*Mandatory

Vehicle Service Parts (may be required for reassembly)

Item #	Quantity Req'd.	Description
1		
2		
3		

Legend

 **STOP:** Damage to the vehicle may occur. Do not proceed until process has been complied with.

 **OPERATOR SAFETY:** Use caution to avoid risk of injury.

 **CAUTION:** A process that must be carefully observed in order to reduce the risk of damage to the accessory/vehicle and to ensure a quality installation.

 **TOOLS & EQUIPMENT:** Used in Figures calls out the specific tools and equipment recommended for this process.

 **REVISION MARK:** This mark highlights a change in installation with respect to previous issue.

 **SAFETY TORQUE:** This mark indicates that torque is related to safety.

Care must be taken when installing this accessory to ensure damage does not occur to the vehicle. The installation of this accessory should follow approved guidelines to ensure a quality installation.

These guidelines can be found in the "Accessory Installation Practices" document.

This document covers such items as:-

- Vehicle Protection (use of covers and blankets, cleaning chemicals, etc.).
- Safety (eye protection, rechecking torque procedure, etc.).
- Vehicle Disassembly/Reassembly (panel removal, part storage, etc.).
- Electrical Component Disassembly/Reassembly (battery disconnection, connector removal, etc.).

Please see your Toyota dealer for a copy of this document.

1. Assemble the Linkage to the Mounting Bracket.

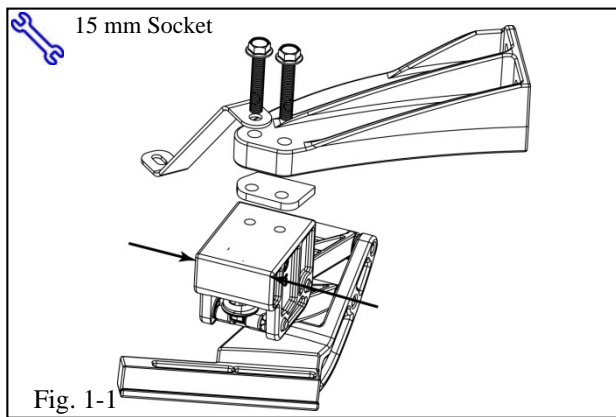

- (a) With the linkage assembly secure in a vice at the points indicated by the arrows, bolt the linkage assembly to the mounting bracket with the spacer and reinforcement bracket (Fig. 1-1). Tighten but do not torque.

- + (1) Keep the linkage assembly in the closed (or stowed) position.
- (2) Protect (cover) the part with cloth when placed in the vice to prevent paint damage.

2. Remove the Bumper Cap.

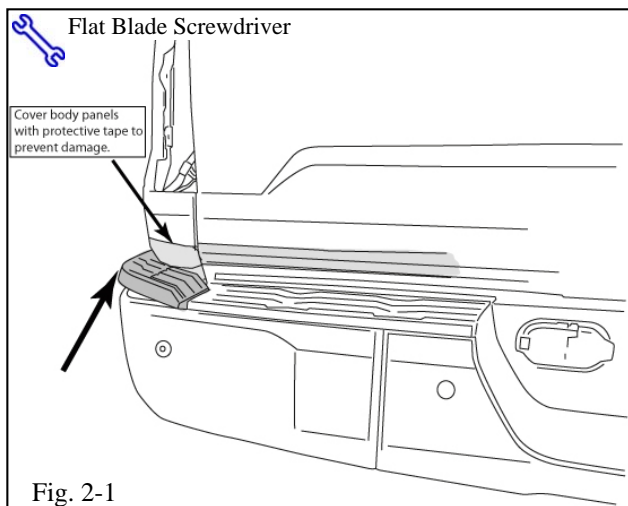

- ⚠ (a) Add protective tape to the body above the bumper cap and tailgate on the driver's side of the vehicle. From the underside of the bumper, press the tabs holding the bumper outer cap in place. Use a large flat blade screwdriver to press the tabs inward (Fig. 2-1). Use caution when removing tabs.

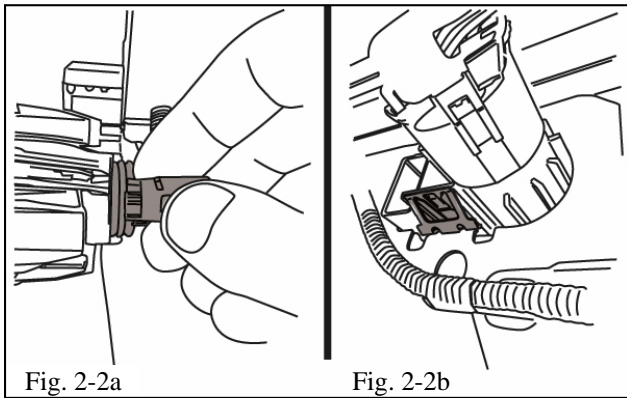

- (b) Remove the license plate light (Fig. 2-2a).
Remove the trailer hitch plug from the socket by pressing the metal tabs. Plug removal is not required (Fig. 2-2b).

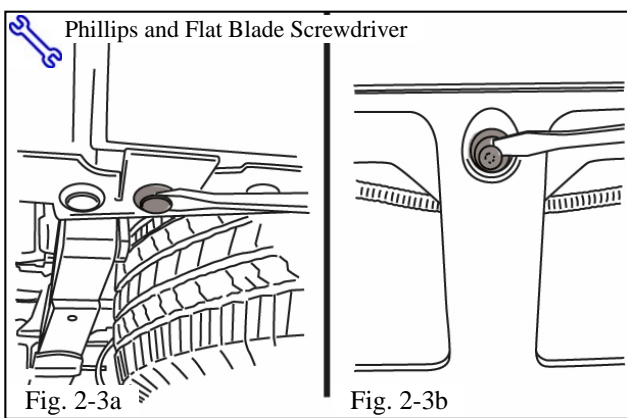

- (c) Remove the plastic plug holding the bumper cap onto the lower portion of the bumper (Fig. 2-3a). Remove the plug behind the license plate in the center of the bumper using a Phillips screwdriver to remove the plastic pin (Fig. 2-3b).

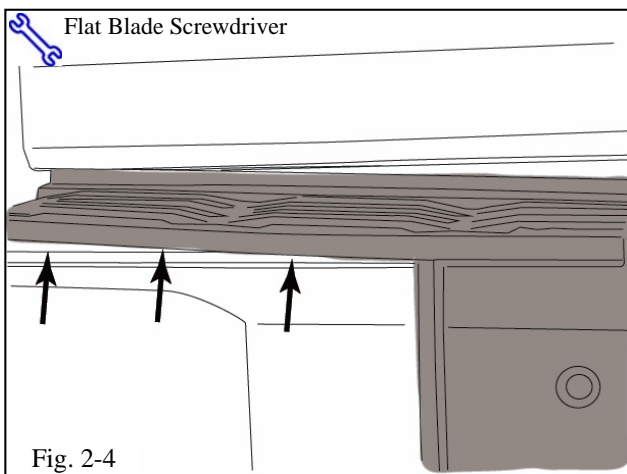

- (d) Lightly pull up on the bumper inner cap and from the underside of the bumper, press the tabs holding the cap in place. Use a large flat blade screwdriver when pressing the tabs inward (Fig. 2-4).

3. Remove the Factory Bumper Support Bracket.

(a) Unbolt the four lower screws holding the bracket in place (Fig. 3-1).

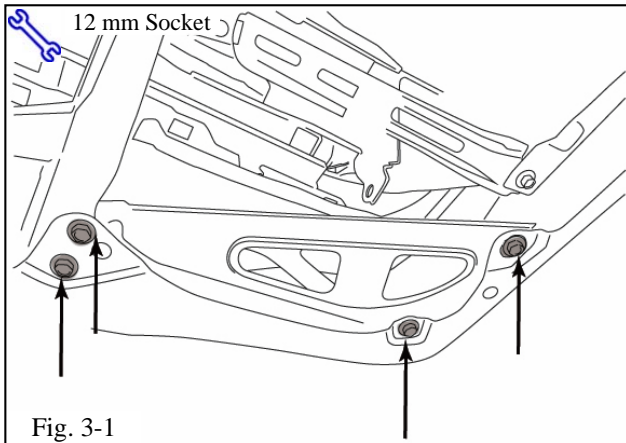

+ (b) Pull the bumper inner cap away from the bumper and remove the two upper mounting screws (black arrows) holding the bracket in place (Fig. 3-2).

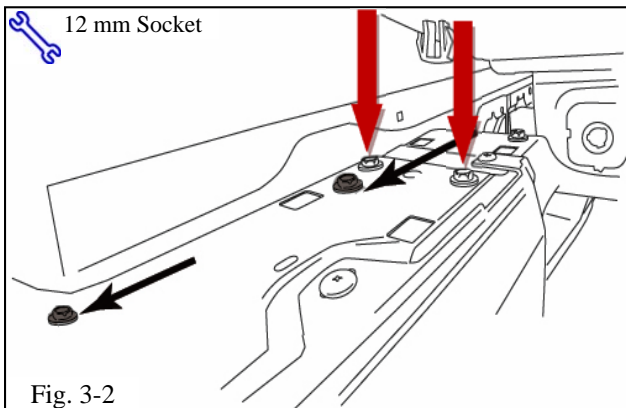

(c) Loosen, but do not remove, the two bolts indicated by the red arrows in Fig. 3-2 to allow small movement of the reinforcement for additional clearance.

|| (d) Remove the factory bracket by rotating and moving it towards the centerline of the vehicle (Fig. 3-3).

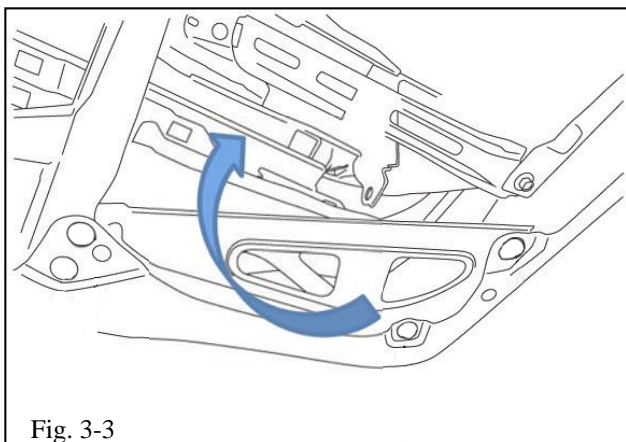

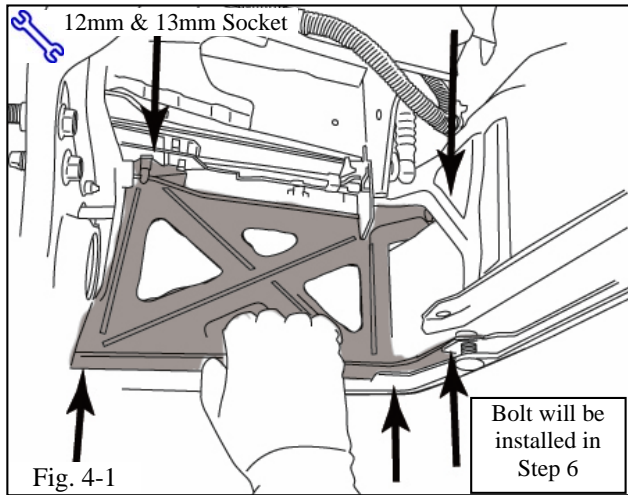

4. Install the Provided Reinforcement Bracket.

- ⚠ (a) Install the provided bracket in place of the factory bracket. Reuse the factory bolts and use the provided M8 nuts to secure it. Leave the forward-most lower bolt out until the linkage assembly is in place. Torque the hex bolts to 27 N·m (20 ft-lbs) (Fig. 4-1).

Torque: 27 N·m (20 ft-lbf)

- (b) Replace the bumper components removed in Step 2.

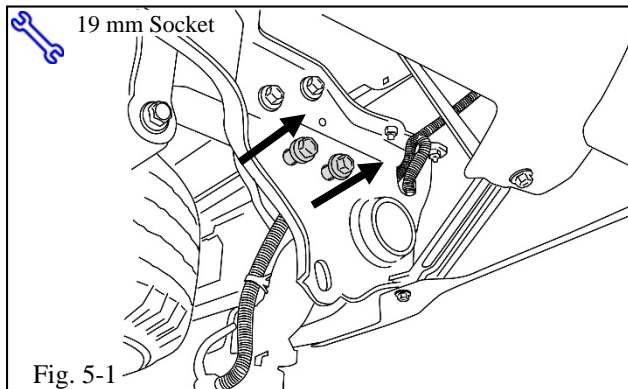

5. Locate and Prepare the Mounting Point.

- (a) Locate the rear bumper attachment point on the driver's side (Fig. 5-1).
- (b) Remove the two bumper fasteners with a ratchet wrench and 19mm socket (Fig. 5-1).

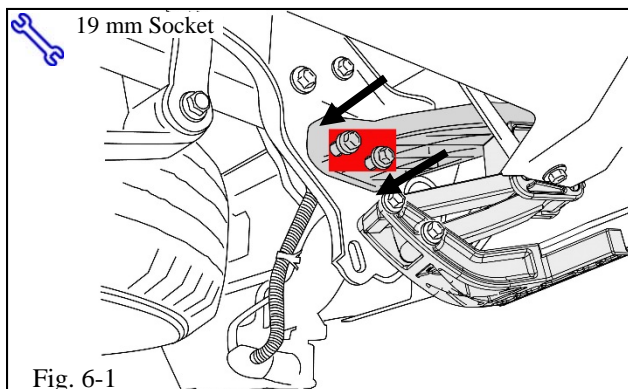

6. Install the Bumper Step Assist to the Mounting Point.

- ⊕ (a) Rotate the bumper step assist assembly into position and install the mounting bracket using the factory fasteners removed in Step 5. Align the bumper support bracket to the mounting hole in the reinforcement bracket.
- (b) Keep the linkage assembly in the lowered position (Fig. 6-1).
 - (1) Torque the fasteners to 152 N·m (112 ft-lbs) (Fig. 6-1).

⚠ **Torque: 152 N·m (112 ft-lbf)**

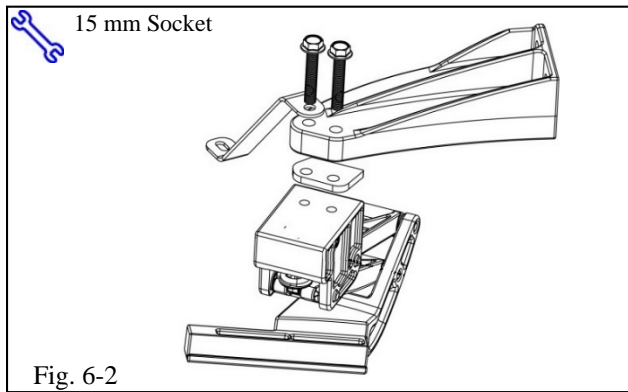

(2) Torque the fasteners from Step 1 to 44 N·m (33ft-lbs) (Fig. 6-2).

S Torque: 44 N·m (33 ft-lbf)

(3) Torque the remaining M8 hardware from Step 4 to 27 N·m (20 ft-lbs) (See Fig. 4-1).

Torque: 27 N·m (20 ft-lbf)

7. Prepare to Install the Step Pad.

- (a) Push the linkage assembly into the lowered position.
- (b) Insert the three nut plates into the designated slots (Fig. 7-1).
 - (1) The raised lip of the nut plate faces upward.
 - (2) Use the first, second and fourth slots only.

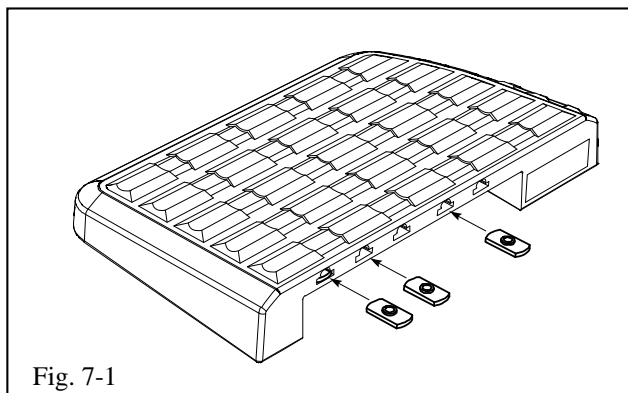

8. Install the Step Pad.

- (a) Locate the step pad onto the mount of the linkage assembly.

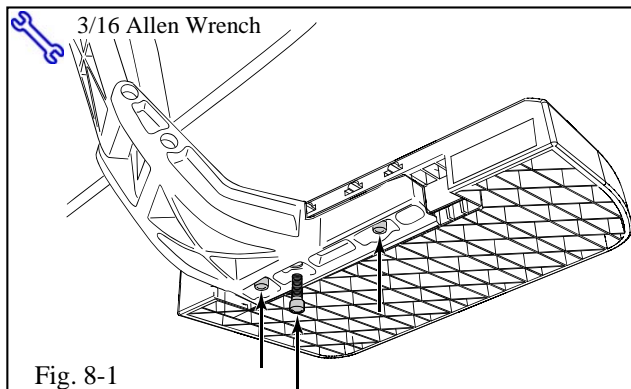

- (1) The step pad interface allows two positions. Use the position that extends the step pad most outboard (Fig. 8-1).

- (2) This arrangement allows foot access for deploying the step (Fig. 8-2).

- (b) Insert the cap screws into the corresponding holes (first, second and forth) and torque to 8 N·m (6 ft-lbs) (Fig. 8-1).

Torque: 8 N·m (6 ft-lbf, 71 in-lbf)

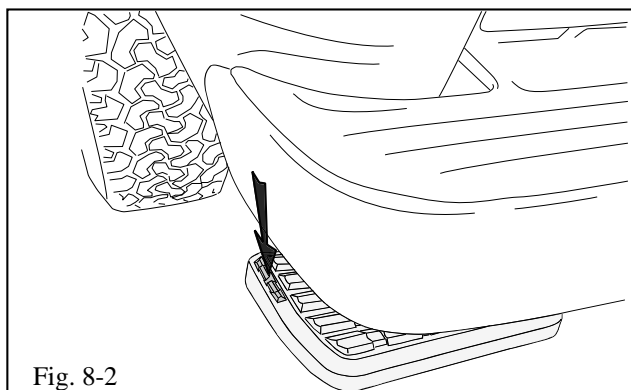

TOYOTA TUNDRA 2014 - BUMPER STEP ASSIST
 Checklist - these points **MUST** be checked to ensure a quality installation.

Check:	Look For:
<p><u>Accessory Function Checks</u></p> <p><input type="checkbox"/> Torque adjustment of linkage to mounting bracket bolts</p> <p><input type="checkbox"/> Torque adjustment of brackets / linkage assembly bolts</p> <p><input type="checkbox"/> Torque adjustment of step pad screws Process check: An auditor will confirm the torque wrench setting and observe the installer performing the process.</p> <p><u>Note:</u> The bolts may loosen 1ft-lb over the first 24 hour period. This is very common with plastic components and is commonly referred to as “creep” in the plastic industry. THIS IS NOT A SAFETY ISSUE.</p> <p><input type="checkbox"/> Step pad position</p> <p><input type="checkbox"/> License plate light</p> <p><input type="checkbox"/> Bumper inner caps</p>	<p><u>Look For:</u></p> <p>Linkage to mounting bracket bolts must be tightened to 44 N·m (33 ft-lbs)</p> <p>Brackets / linkage assembly bolts must be tightened to 152 N·m (112 ft-lbs)</p> <p>M8 hardware must be tightened to 27 N·m (20 ft-lbs)</p> <p>Step pad screws must be tightened to 8 N·m (6 ft-lbs, 71 in-lbf)</p> <p>Ensure foot access for deployment. The step deploys with downward force to the left leading corner (indicated by the raised grip section).</p> <p>Verify it illuminates properly.</p> <p>Not loose and cannot be lifted. If they are loose, re-spread the tabs so the caps reengage and hold.</p>
<p><u>Vehicle Appearance Check</u></p> <p><input type="checkbox"/> After accessory installation and removal of protective cover(s), perform a visual inspection</p>	<p>Ensure no damage (including scuffs and scratches) was caused during the installation process.</p> <p>(For PPO installations, refer to TMS Accessory Quality Shipping Standard.)</p>